

NAME	DATE	REVISIONS	MOLD NO.			A3	DRUJBA Glassworks S.A. A Member of Yioula Group	
			FINISH	FIN 057			BOTTLE	
			CAP. BRIMF.	516 ± 10ml	MACHINE		50cl TERESA	
			CAP. FILLPT.	500 ± 10ml	DATE	10/11/2005	CAT.No & DWG No	
			FILL LINE	80 mm	DRAWN	Stanchev	1093057	
			WEIGHT	570 gr	CHECKED	Angelov	SHEET: 1/1 SCALE: 1:1	
			COLOR		CONFIRMED			

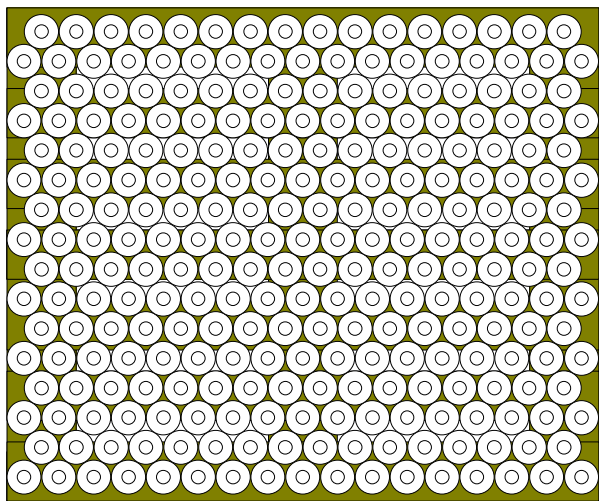

1200.0

1000.0

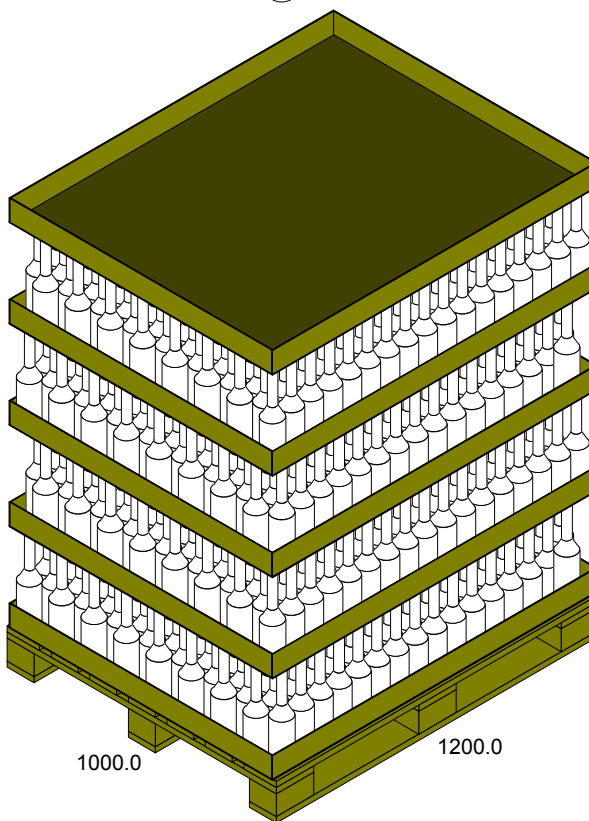
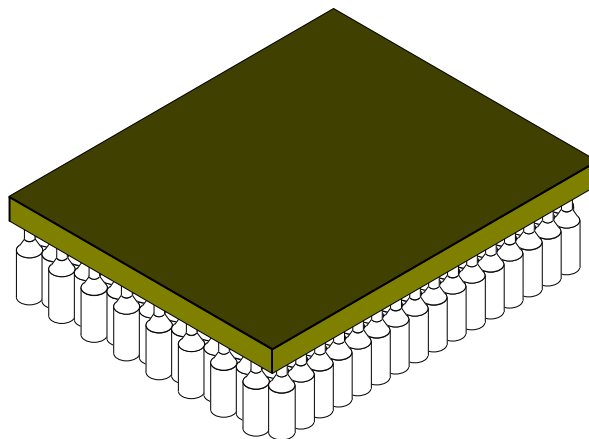

DRUJBA PALLET 09 1200.0x1000.0x134.0

	Bottle (ID)	Bottle (OD)	UnitLoad (Incl. Pal)
Ln:	69.80 mm	69.80 mm	1200.0 mm
Wd:	69.80 mm	69.80 mm	1000.0 mm
Ht:	323.50 mm	323.50 mm	1782.0 mm
Net:		570.00 g	752.400 kg
Grs:		0.00 g	22.000 kg
Cube:	0.905 l	0.9 l	2.1384 m3

Bottle: 1320
 Area Efficiency: 107.18 %
 Cubic Efficiency: 50.63 %
 Cases per layer: 264
 Layers/load: 5
 Pattern: Staggered

Notes: THE WOODEN PALLET IN USE IS SPECIALLY FUMIGATED